

FOUR(4) M3X21mm
FLAT HEAD SCREWS

$\phi 2.50\text{mm}$ [0.098in]

SECTION B-B

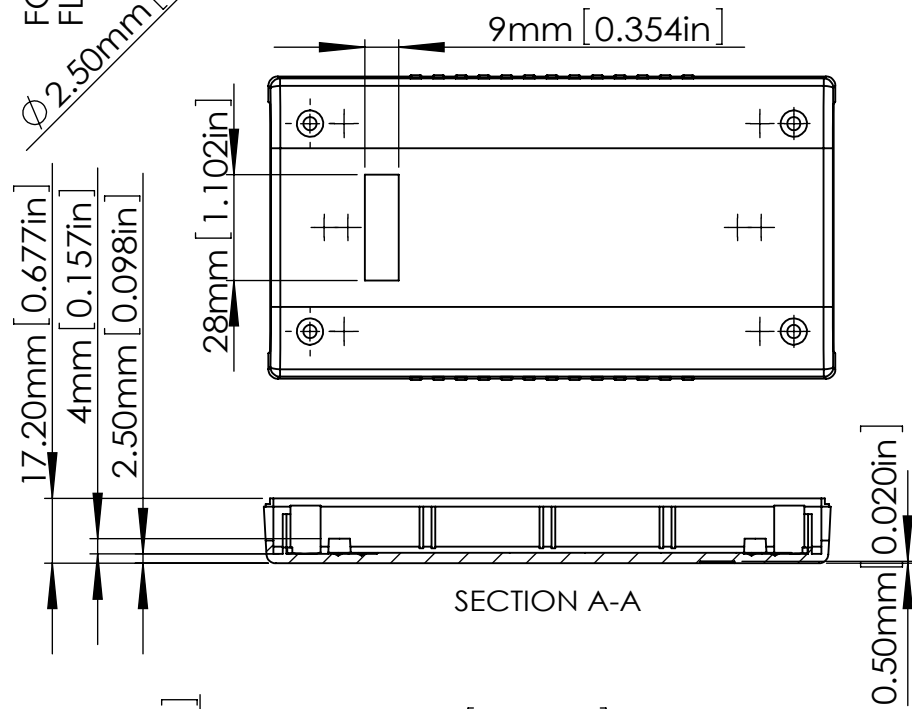

SECTION A-A

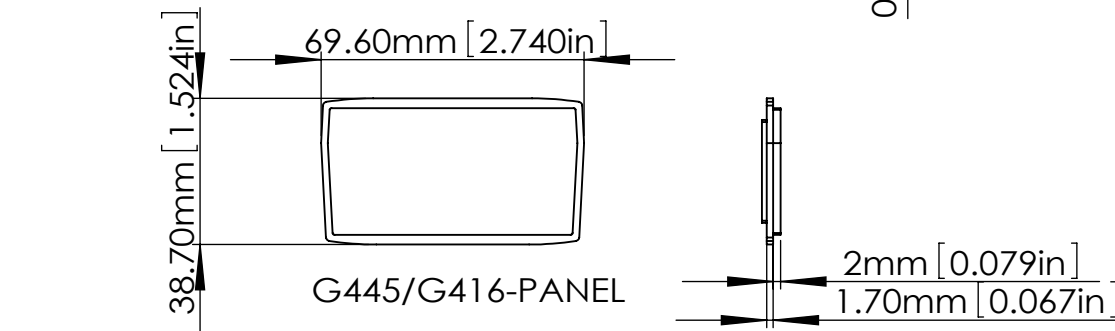

G445/G416-PANEL

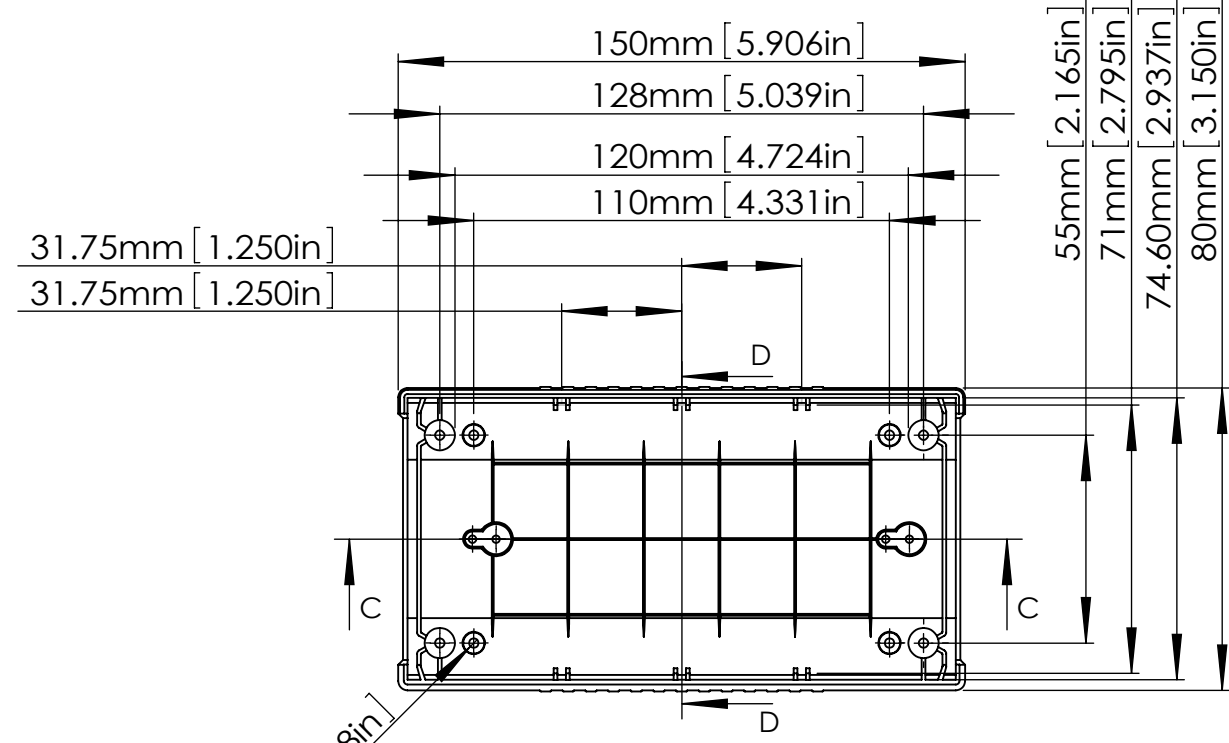

SECTION D-D

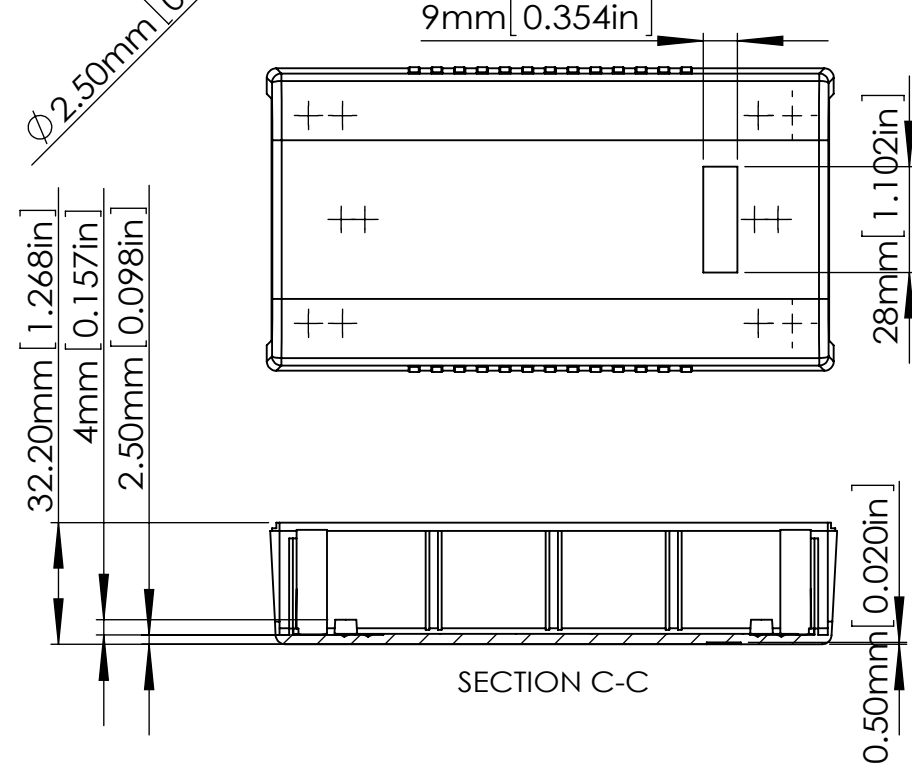

SECTION C-C

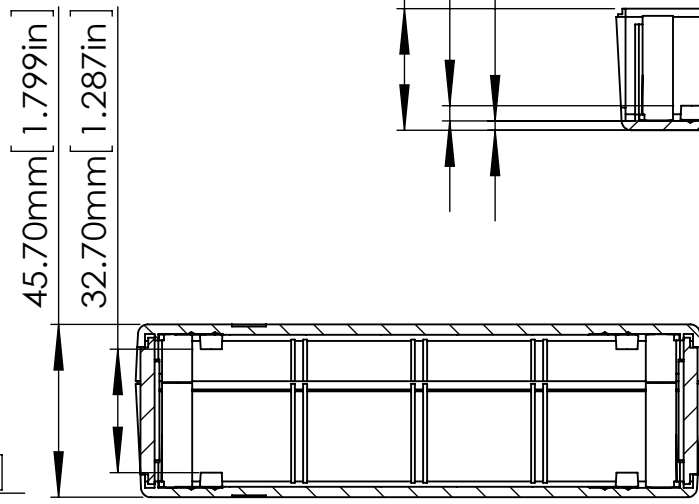

ASSEMBLY

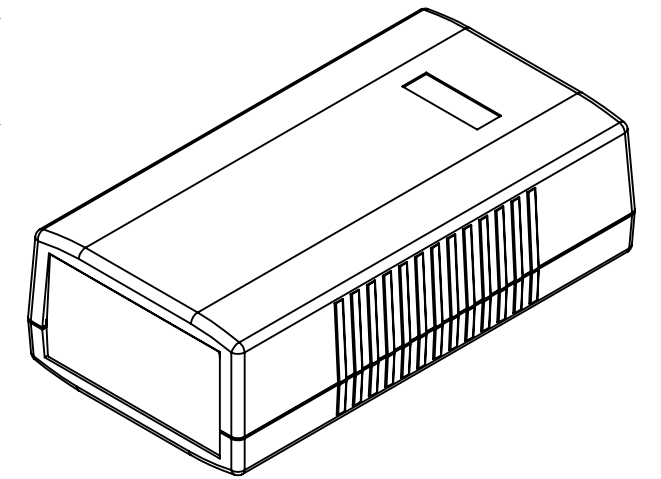

According to ISO 2768-m	
Measuring DIM=L	Tolerances
0.5<L<=3.0mm	±0.1mm
3.0<L<=6.0 mm	±0.1mm
6.0<L<=30.0 mm	±0.2mm
30.0<L<=120.0 mm	±0.3mm
120.0<L<=400.0 mm	±0.5mm
400.0<L<=1000.0 mm	±0.8mm

宣又實業有限公司
GAINTA INDUSTRIES LTD.

繪圖 DRA'D BY
JACKY

日期 DATE
2021/12/08

材質 MATE.
ABS

圖名TITLE:
G445 G416

圖號DWG NO:

版次REVISID:

C